

**Narada**<sup>®</sup>

**Polymer Gel Standby Battery**

---

**MPG Series**

**OPERATION  
MANUAL**

Version: V4.6

---

**Zhejiang Narada Power Source Co., Ltd.**





## Contents

Security Instructions .....	3
Chapter One Product Introduction .....	4
1.Features .....	4
2. Main Applications .....	4
3. Types and Dimensions .....	5
4. Dimension and Sketch Map .....	5
5. Terminals Sketch Map.....	7
Chapter Two Technical Characteristics .....	8
1. Charge Characteristics Curve.....	8
2. Discharge Characteristics Curve .....	8
3. Internal resistance and short circuit current .....	9
4. Constant Current and Power Discharge Data.....	10
Chapter Three Operation and Maintenance.....	17
1. Operation Condition.....	17
2. Capacity .....	17
3. Temperature .....	18
4. Charge and discharge requirements .....	21
5. Storage .....	22
6. Maintenance.....	23
Annex 1 .....	26











### Safety and Warning

Please read this manual! It provides very important direction for fix and operation, which can make best capability for the equipment, and elongate the using life.

- For your safety, please do not try to dismantle or open the equipment. The equipment does not contain any spare parts for you. The maintain work can only be done by specially trained service persons.
- As a result of the batteries' latent endanger to heath and environment, they should be only changed in our authorization service center. If you need to change the battery or maintain the equipment, please call the nearest service center.
- Batteries can be reclaimed, if it could not be carefully handled, it will do great harms to environment and heath. Please check local laws and regulations to get the validity handle ways or send the equipment to authorized service center.
- The replacement of battery can only be done by persons who know well about the danger and the prevention. When changing the battery, please use the same model and type of sealed gel battery.

-  Warning—do not smoke or use fire near batteries.
-  Warning—do not use organic solvent to wash batteries
-  Warning—dot not put batteries into the fire, or it may bombed.
-  Warning—do not open batteries, it contains electrolyte, which can hurt the skin and eyes.
-  Warning—There may happen shock or short circuit when replacing the batteries. Please operate with tools with insulated handles.

Please take care of the following marks in using

					
Warning	Electricity danger	Protecting your eye	Watch Short-circuits	With adults custody	Do not put batteries into dustbin
					
Read the manual	Fire forbidden	Circle used	The product has past the UL authentication	The product has past the CE authentication	

## Chapter One Product Introduction

### **1. Technical Features**

#### **1.1. Gel technology**

- 1.1.1. Using polymer gel electrolyte
- 1.1.2. Special Paste Formula
- 1.1.3. Special Patented grid alloy
- 1.1.4. Thick Plate Design
- 1.1.5. Through-the-ports Welding and low internal resistance

#### **1.2. Reliable Seal Technology**

- 1.2.1. High precise ABS heat seal technology;
- 1.2.2. The seal recombination efficiency reaches up to 99.0%;
- 1.2.3. Reliable post seal structure;
- 1.2.4. Integrated valve design to ensure precise and reliability.

#### **1.3. Excellent high rate discharge performance**

- 1.3.1. Through-the-portion Welding and low internal Resistance.
- 1.3.2. Radical Grid Design.
- 1.3.3. Patented Paste Technology.
- 1.3.4. Silver Coated Flexible Connector

#### **1.4 Front terminal rack design**

- 1.4.1. Excellent Heat Dispersing Ability
- 1.4.2. Positive and Negative Terminals on the Same Side. Easy for Monitoring and Maintenance.
- 1.4.3. Flexible Connector for Flexible installation.

### **2. Main Applications**

- 2.1. Communication System
- 2.2. UPS
- 2.3. Electricity Power System
- 2.4 Other applications to provide integrated stored energy system

3. Types and Dimensions

Tab.1-1 Types and Dimensions

Type	Normal Voltage (V)	Rated Capacity C <sub>10</sub> (Ah)	Dimensions(mm)			Weight (Kg)
			Length	Width	Height	
MPG12V50F	12	50	390	105	227	20.7
MPG12V65F	12	65	395	105	270	24.5
MPG12V85F	12	85	395	105	270	28.0
MPG12V100F	12	100	558	125	227	38.0
MPG12V105F	12	100	511	110	238	34.0
MPG12V125F	12	125	558	125	270	48.0
MPG12V150F	12	150	558	125	310	52.0
MPG12V150FA	12	150	558	125	310	57.5
MPG12V155F	12	155	559	125	283	53.0
MPG12V170F	12	170	558	125	310	55.5
MPG12V200	12	200	498	259	238	71.0

4. Dimension and Sketch Map

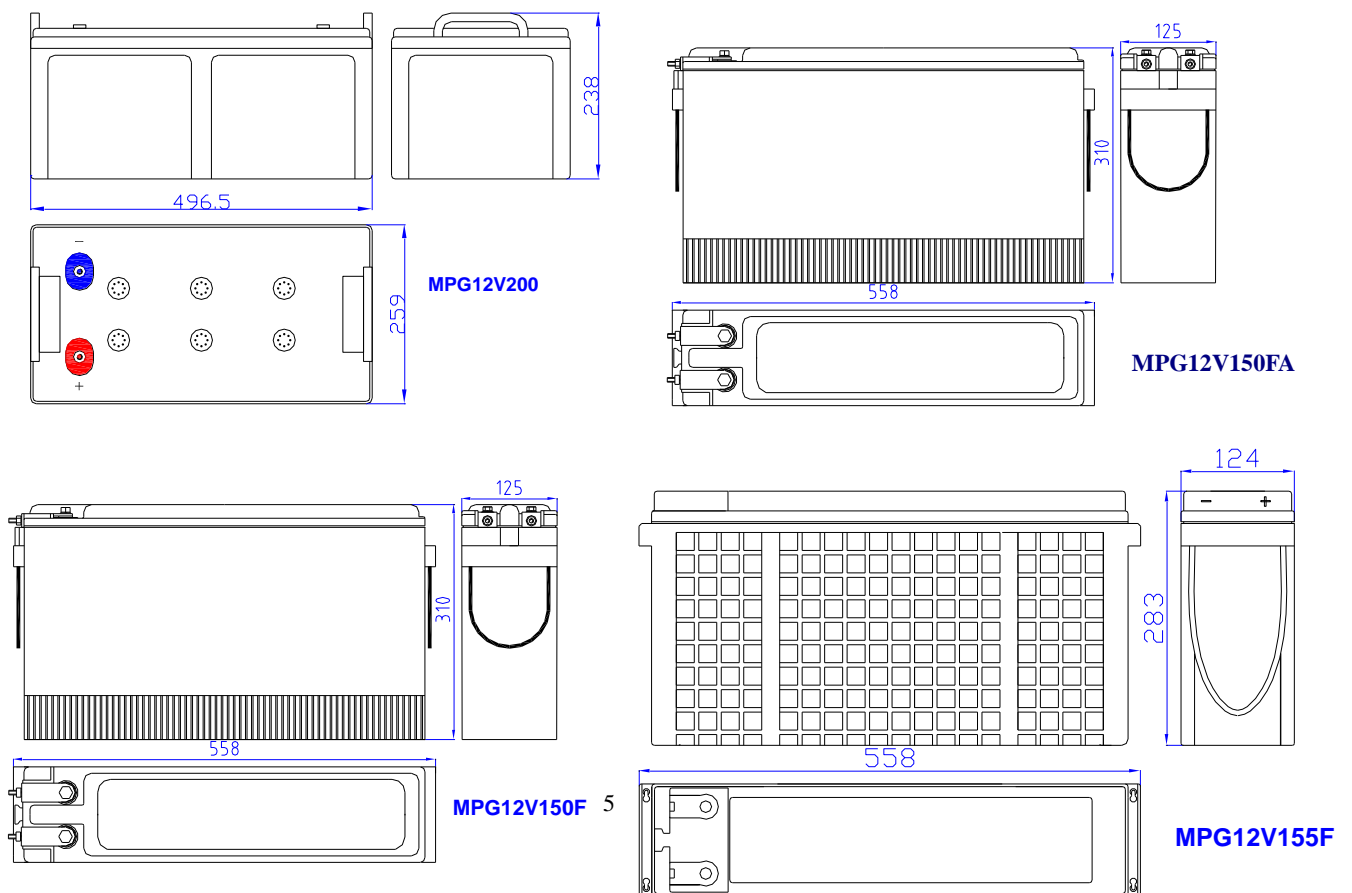

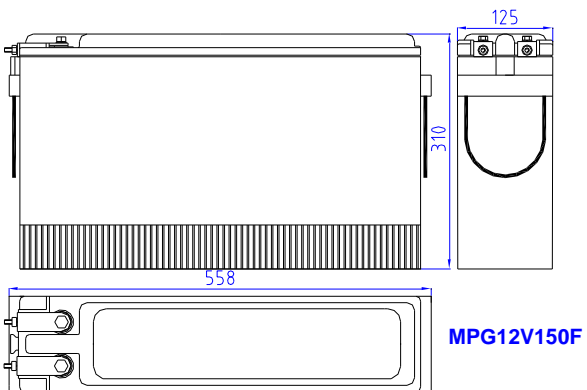
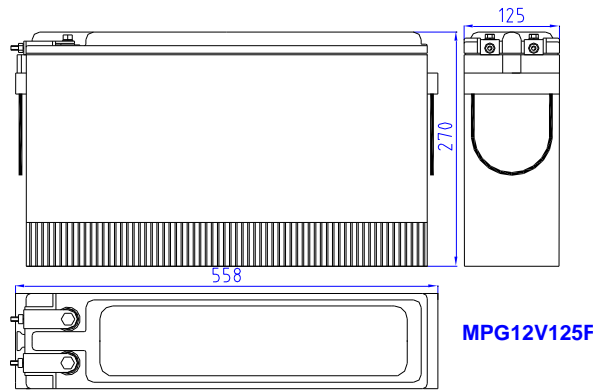
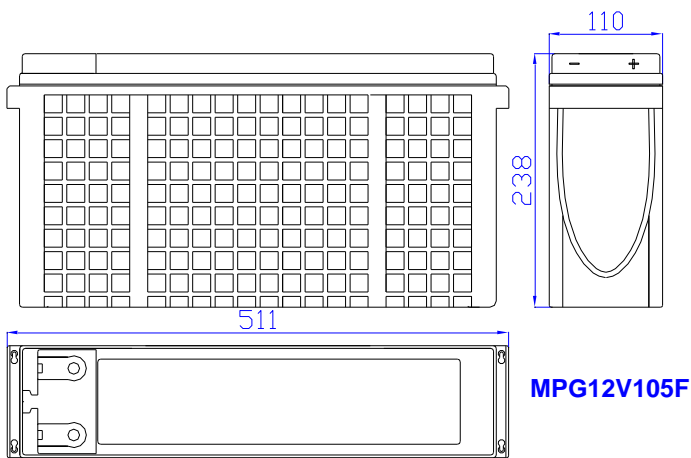
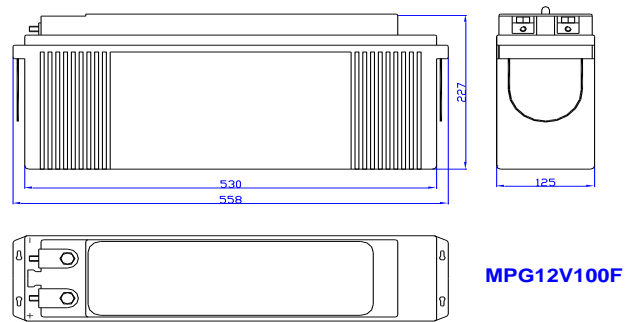
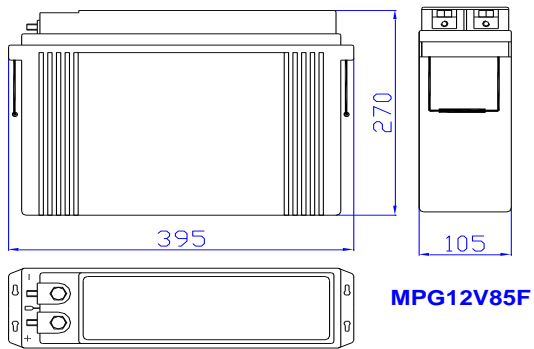
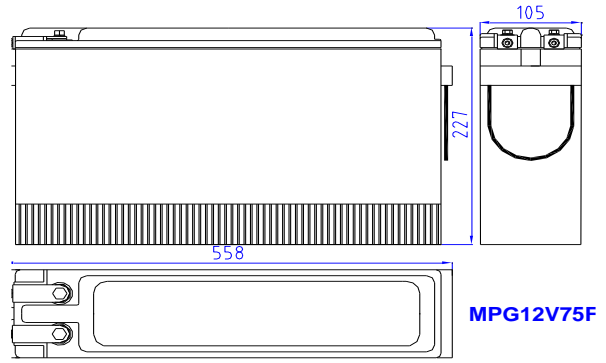
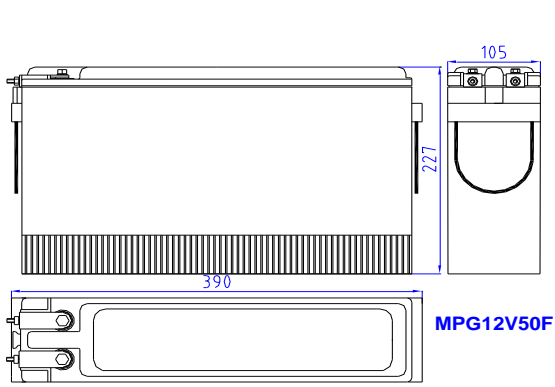

### 5. Terminals Sketch Map

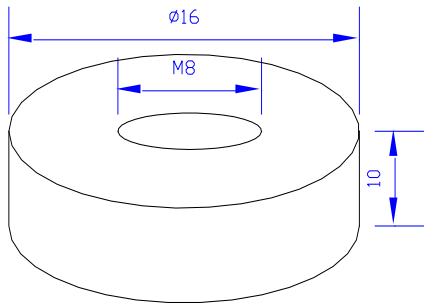

MPG12V100 MPG12V200

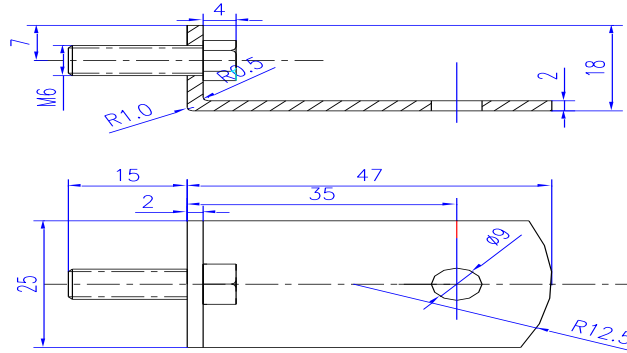

MPG12V100F MPG12V105F  
MPG12V155F

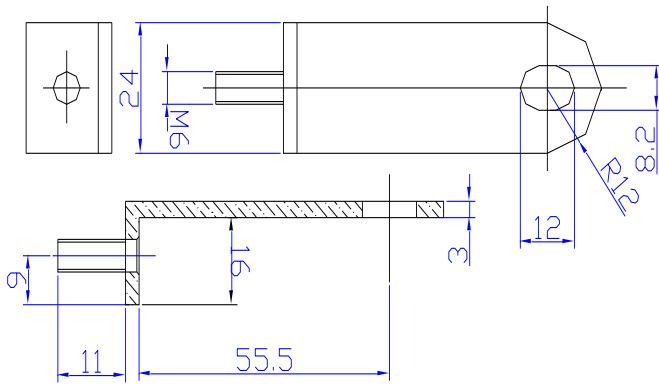

MPG12V75F, MPG12V125F, MPG12V150F

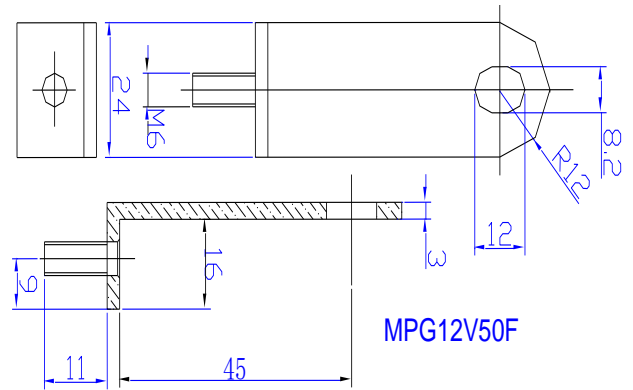

MPG12V50F

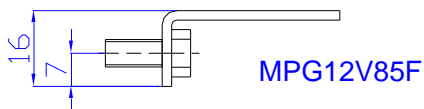
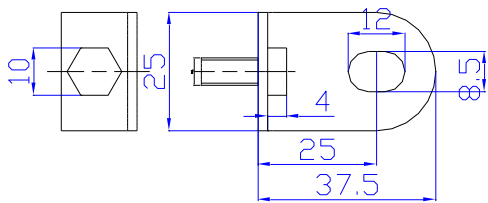

MPG12V85F

**Chapter Two Technical Characteristics**

**1. Charge Characteristics Curve**

Fig. 2-1 The battery voltage vs charge time curves at 25°C

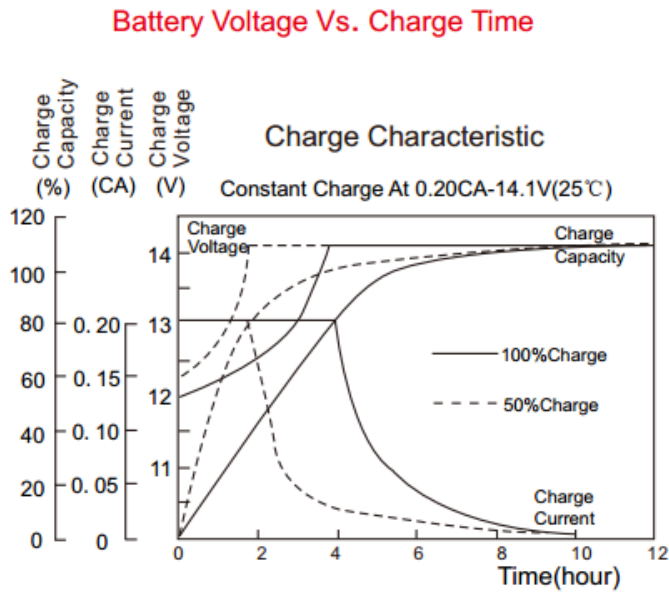

Fig.2-1 Charge Curve at 25°C

**2. Discharge Characteristics Curve**

Fig.2-2 The terminal voltage vs discharge time curves at different current at 25°C.

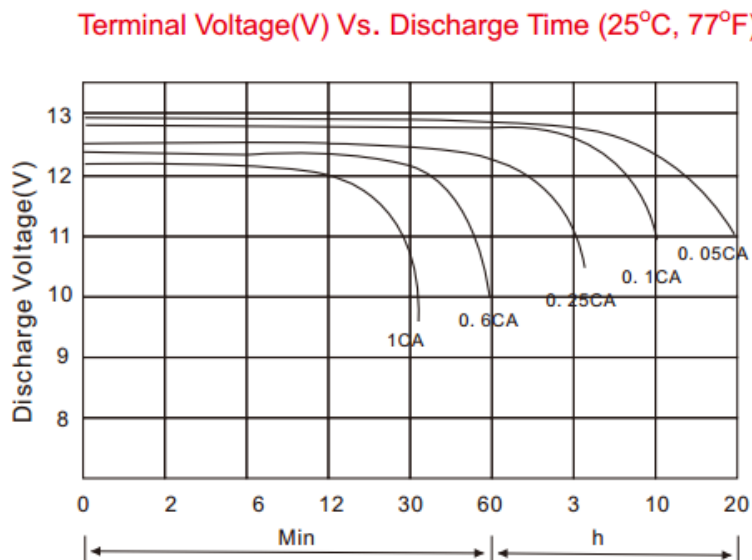

Fig.2-1 Discharge Curve at different current at 25°C



### 3. Internal resistance and short circuit current

The internal resistance of the battery is a dynamic nonlinear parameter that is continuously changed along with the temperature and discharge state. The internal resistance is the lowest when battery is fully charged. The table 2-1 shows the internal resistance and short circuit current in fully charged state

Table 2-1 Internal resistance and short circuit (25°C)

Type	Internal Resistance(mΩ)	Short Circuit Current (A)
MPG12V50F	8.39	1487
MPG12V65F	7.50	1720
MPG12V85F	6.79	1880
MPG12V100F	5.55	2290
MPG12V105F	5.45	2337
MPG12V125F	3.91	3151
MPG12V150F	4.55	3223
MPG12V150FA	3.91	3200
MPG12V155F	3.10	3230
MPG12V170F	3.03	3873
MPG12V200	2.83	4187

Note: Short circuit current will decrease the voltage of the battery to 0V, and damage the internal components of the battery.

4. Constant Current and Power Discharge Data

**Table 2-2 Constant current discharge characteristic Units: Amperes(25°C)**

MPG12V50F															
End voltage per cell	5min	15min	30min	45min	1h	2h	3h	4h	5h	6h	8h	10h	12h	20h	24h
1.60V	164	88	53	39	31.2	17.9	14.0	10.8	9.6	8.1	6.3	5.2	4.40	2.73	2.28
1.67V	154	85	52	38	31.0	17.8	13.8	10.7	9.5	8.1	6.2	5.1	4.35	2.71	2.26
1.70V	152	83	52	38	30.8	17.7	13.7	10.7	9.4	8.1	6.2	5.1	4.31	2.70	2.26
1.75V	140	81	51	38	30.4	17.2	13.5	10.6	9.3	8.0	6.2	5.1	4.31	2.69	2.26
1.80V	126	75	49	36	29.6	17.1	13.5	10.5	9.1	7.8	6.1	5.0	4.28	2.67	2.25
1.83V	120	69	48	35	28.3	16.8	13.0	10.0	8.8	7.6	6.0	4.8	4.10	2.66	2.22
1.85V	112	67	45	34	27.4	16.2	12.7	9.9	8.6	7.4	5.8	4.8	4.08	2.61	2.20
MPG12V85F															
End voltage per cell	5min	15min	30min	45min	1h	2h	3h	4h	5h	6h	8h	10h	12h	20h	24h
1.60V	316	170	103	75	60.2	34.5	25.0	19.7	16.6	14.3	10.9	9.0	7.57	4.74	3.96
1.67V	297	164	102	74	59.8	34.3	24.6	19.6	16.5	14.2	10.8	8.9	7.56	4.70	3.93
1.70V	294	161	100	74	59.4	34.0	24.5	19.5	16.3	14.1	10.8	8.9	7.49	4.69	3.93
1.75V	271	156	99	73	58.5	33.2	24.2	19.2	16.2	13.9	10.7	8.8	7.49	4.68	3.92
1.80V	243	146	95	70	57.0	32.9	24.0	19.2	15.9	13.7	10.6	8.7	7.42	4.63	3.92
1.83V	232	133	93	68	54.5	32.5	23.2	18.3	15.3	13.2	10.3	8.4	7.06	4.62	3.85
1.85V	217	129	86	65	52.8	31.3	22.6	18.1	15.0	12.9	10.0	8.3	6.98	4.53	3.82
MPG12V100F															
End voltage per cell	5min	15min	30min	45min	1h	2h	3h	4h	5h	6h	8h	10h	12h	20h	24h
1.60V	365	196	118	86.1	69.5	39.8	28.8	22.7	19.1	16.4	12.6	10.4	8.73	5.47	4.57

1.67V	342	189	117	85.5	69.0	39.6	28.4	22.6	19.0	16.3	12.5	10.3	8.72	5.42	4.53
1.70V	339	186	115	84.9	68.5	39.2	28.2	22.5	18.8	16.2	12.5	10.2	8.64	5.41	4.53
1.75V	312	180	114	84.3	67.5	38.3	27.9	22.1	18.6	16.0	12.4	10.1	8.64	5.40	4.52
1.80V	280	168	109	80.8	65.7	38.0	27.7	22.1	18.3	15.7	12.3	10.0	8.56	5.34	4.52
1.83V	267	153	107	78.1	62.9	37.5	26.7	21.1	17.6	15.2	11.9	9.7	8.14	5.33	4.44
1.85V	250	149	100	75.0	60.9	36.1	26.0	20.8	17.2	14.8	11.6	9.6	8.05	5.23	4.41
MPG12V105F															
End voltage per cell	5min	15min	30min	45min	1h	2h	3h	4h	5h	6h	8h	10h	12h	20h	24h
1.60V	375	202	122	89	71.3	40.9	29.6	23.3	19.7	16.9	12.9	10.6	8.97	5.62	4.69
1.67V	353	195	120	88	70.9	40.7	29.1	23.1	19.6	16.8	12.8	10.5	8.96	5.57	4.65
1.70V	349	192	118	87	70.3	40.4	28.9	23.0	19.3	16.5	12.7	10.5	8.87	5.56	4.65
1.75V	321	186	117	87	69.3	39.3	28.6	22.8	19.2	16.4	12.6	10.4	8.87	5.55	4.64
1.80V	288	173	112	83	68.0	39.0	28.4	22.7	18.8	16.1	12.5	10.3	8.80	5.49	4.63
1.83V	274	158	110	80	64.6	38.5	27.5	21.7	18.1	15.5	12.2	9.9	8.37	5.48	4.56
1.85V	257	153	103	77	62.5	37.0	26.7	21.4	17.7	15.2	11.8	9.9	8.26	5.38	4.52
MPG12V125F															
End voltage per cell	5min	15min	30min	45min	1h	2h	3h	4h	5h	6h	8h	10h	12h	20h	24h
1.60V	408	219	133	96	77.8	44.7	34.9	26.8	24.1	20.2	15.8	13.1	10.94	6.83	5.70
1.67V	384	212	131	96	77.4	44.4	34.3	26.7	23.9	20.2	15.6	13.0	10.84	6.77	5.65
1.70V	380	208	129	95	76.8	44.1	34.1	26.5	23.6	20.2	15.6	12.8	10.74	6.75	5.65
1.75V	349	202	128	94	75.7	43.0	33.7	26.2	23.3	20.0	15.4	12.7	10.74	6.74	5.64
1.80V	313	188	123	91	73.7	42.6	33.5	26.2	22.7	19.6	15.3	12.6	10.64	6.67	5.63
1.83V	299	172	120	88	70.5	42.1	32.4	24.9	22.0	18.9	14.9	12.0	10.24	6.66	5.54
1.85V	280	167	112	84	68.4	40.5	31.5	24.6	21.5	18.5	14.5	11.9	10.14	6.53	5.49

MPG12V150F															
End voltage per cell	5min	15min	30min	45min	1h	2h	3h	4h	5h	6h	8h	10h	12h	20h	24h
1.60V	571	307	186	135	108.4	62.3	45.2	35.4	29.9	25.7	19.8	16.3	13.65	8.57	7.16
1.67V	537	296	183	134	108.4	61.9	44.4	35.2	29.8	25.5	19.6	16.0	13.65	8.50	7.10
1.70V	532	291	180	133	107.4	61.4	44.2	35.0	29.3	25.3	19.5	16.0	13.55	8.48	7.10
1.75V	488	282	178	132	105.4	59.9	43.6	34.6	29.1	25.1	19.3	16.0	13.55	8.45	7.09
1.80V	438	263	171	127	102.4	59.4	43.4	34.5	28.5	24.6	19.2	15.8	13.45	8.37	7.08
1.83V	417	241	168	122	98.4	58.6	41.9	33.0	27.6	23.8	18.7	15.2	12.75	8.35	6.96
1.85V	391	234	156	118	95.4	56.5	40.8	32.5	26.9	23.2	18.2	15.1	12.65	8.19	6.91
MPG12V155F															
End voltage per cell	5min	15min	30min	45min	1h	2h	3h	4h	5h	6h	8h	10h	12h	20h	24h
1.60V	502	270	164	119	96.1	55.1	43.2	33.1	28.9	25.1	19.5	16.1	13.65	8.46	7.07
1.67V	472	260	161	118	95.6	54.8	42.4	32.9	28.7	25.0	19.3	15.8	13.45	8.39	7.01
1.70V	468	256	159	117	94.9	54.4	42.2	32.8	29.3	25.0	19.3	15.9	13.35	8.37	7.01
1.75V	430	248	158	116	93.5	53.0	41.7	32.4	28.8	24.8	19.1	15.8	13.35	8.35	7.00
1.80V	385	231	151	112	91.1	52.6	41.4	32.3	28.1	24.3	19.0	15.6	13.25	8.27	6.99
1.83V	367	211	148	108	87.1	51.9	40.1	30.8	27.2	23.4	18.5	15.0	12.75	8.25	6.88
1.85V	344	205	137	104	84.4	50.0	39.0	30.4	26.5	22.9	17.9	14.9	12.65	8.09	6.82
MPG12V170F															
End voltage per cell	5min	15min	30min	45min	1h	2h	3h	4h	5h	6h	8h	10h	12h	20h	24h
1.60V	625	336	203	148	119.4	68.2	49.4	38.8	32.8	28.2	21.6	17.8	14.94	9.38	7.84
1.67V	588	324	200	147	118.4	67.8	48.5	38.6	32.6	27.9	21.5	17.6	14.94	9.30	7.77
1.70V	581	318	197	145	117.4	67.3	48.3	38.4	32.1	27.7	21.4	17.6	14.84	9.28	7.76
1.75V	534	309	195	144	115.3	65.6	47.7	37.9	31.9	27.5	21.2	17.5	14.84	9.26	7.76

MPG12V200															
End voltage per cell	5min	15min	30min	45min	1h	2h	3h	4h	5h	6h	8h	10h	12h	20h	24h
1.80V	479	288	187	139	112.3	65.0	47.4	37.8	31.2	26.9	21.1	17.3	14.64	9.17	7.74
1.83V	457	264	183	134	107.3	64.2	45.8	36.1	30.2	26.0	20.5	16.6	13.94	9.15	7.62
1.85V	429	256	171	129	104.3	61.8	44.6	35.6	29.5	25.4	19.9	16.4	13.84	8.97	7.55
1.60V	655	353	214	154	124.5	71.4	55.9	43.0	38.6	32.3	25.2	20.7	17.57	10.94	9.13
1.67V	616	340	210	153	123.5	71.1	54.9	42.7	38.2	32.2	24.9	20.4	17.37	10.84	9.05
1.70V	610	334	207	152	122.5	70.5	54.6	42.5	37.8	32.2	24.9	20.5	17.27	10.84	9.04
1.75V	560	324	205	151	121.5	68.7	54.0	42.0	37.3	31.9	24.6	20.3	17.27	10.74	9.03
1.80V	502	301	197	145	117.5	68.1	53.6	41.9	36.3	31.3	24.5	20.1	17.07	10.64	9.02
1.83V	479	276	193	140	112.4	67.3	51.9	40.0	35.1	30.2	23.9	19.4	16.37	10.64	8.87
1.85V	449	268	178	135	109.4	64.8	50.5	39.4	34.3	29.6	23.1	19.2	16.26	10.44	8.80

**Table 2-3 Discharge data with constant power Units: Watts per cell(25°C)**

MPG12V50F															
End voltage per cell	5min	15min	30min	45min	1h	2h	3h	4h	5h	6h	8h	10h	12h	20h	24h
1.60V	274	154	96	73	58.8	33.8	26.6	20.6	18.5	15.6	12.3	10.0	8.51	5.41	4.53
1.67V	264	152	96	72	58.5	33.7	26.2	20.6	18.4	15.6	12.1	9.9	8.45	5.40	4.53
1.70V	262	150	96	72	58.3	33.5	26.2	20.5	18.2	15.6	12.1	9.9	8.37	5.38	4.52
1.75V	245	149	95	72	57.5	33.4	26.0	20.5	18.1	15.5	12.0	9.9	8.36	5.37	4.52
1.80V	229	141	93	70	57.3	33.3	25.9	20.4	17.7	15.4	12.0	9.8	8.34	5.37	4.51
1.83V	221	129	92	68	54.9	32.9	25.3	19.7	17.4	14.9	11.9	9.6	8.17	5.36	4.48

1.85V	209	126	85	65	53.2	31.8	24.6	19.4	16.9	14.6	11.5	9.5	8.12	5.26	4.44
MPG12V85F															
End voltage per cell	5min	15min	30min	45min	1h	2h	3h	4h	5h	6h	8h	10h	12h	20h	24h
1.60V	529	299	186	140	113.5	65.2	47.6	37.8	31.8	27.4	21.2	17.5	14.64	9.40	7.87
1.67V	510	293	185	139	112.4	65.0	47.0	37.7	31.8	27.2	21.1	17.4	14.64	9.37	7.86
1.70V	507	290	184	139	112.4	64.8	47.0	37.5	31.3	27.0	21.0	17.2	14.54	9.34	7.85
1.75V	478	288	184	139	110.4	64.4	46.5	37.4	31.3	27.0	20.8	17.2	14.54	9.32	7.85
1.80V	439	272	179	136	110.4	64.2	46.4	37.3	30.8	26.7	20.7	17.1	14.44	9.32	7.84
1.83V	426	250	177	132	105.4	63.4	45.3	36.0	30.1	25.9	20.6	16.6	14.04	9.30	7.78
1.85V	403	244	165	126	102.4	61.3	44.1	35.5	29.4	25.4	19.9	16.5	13.94	9.12	7.72
MPG12V100F															
End voltage per cell	5min	15min	30min	45min	1h	2h	3h	4h	5h	6h	8h	10h	12h	20h	24h
1.60V	616	348	217	163	132	75.9	55.4	44.0	37.1	31.9	24.6	20.3	17.1	10.9	9.17
1.67V	593	341	216	162	131	75.7	54.7	43.9	37.1	31.7	24.5	20.2	17.1	10.9	9.16
1.70V	590	338	215	162	131	75.4	54.7	43.7	36.5	31.5	24.4	20.0	16.9	10.9	9.15
1.75V	557	335	215	162	129	75.0	54.1	43.6	36.5	31.5	24.2	20.0	16.9	10.9	9.15
1.80V	511	317	209	158	129	74.7	54.0	43.5	35.9	31.1	24.1	19.9	16.8	10.9	9.14
1.83V	496	291	206	154	123	73.8	52.7	42.0	35.1	30.2	23.9	19.4	16.4	10.8	9.07
1.85V	469	284	192	147	119	71.4	51.3	41.4	34.3	29.6	23.1	19.3	16.2	10.6	9.00
MPG12V105F															
End voltage per cell	5min	15min	30min	45min	1h	2h	3h	4h	5h	6h	8h	10h	12h	20h	24h
1.60V	628	354	221	166	133.5	77.1	56.3	44.6	37.6	32.4	25.1	20.7	17.35	11.13	9.32
1.67V	604	348	219	165	133.5	76.9	55.6	44.5	37.6	32.2	25.0	20.5	17.35	11.13	9.32
1.70V	600	344	219	165	132.5	76.6	55.6	44.3	37.1	32.0	24.8	20.3	17.25	11.03	9.30
1.75V	568	342	218	164	130.5	76.2	55.0	44.3	37.1	31.9	24.6	20.3	17.15	11.03	9.30

1.80V	521	323	213	160	130.5	76.0	54.8	44.2	36.4	31.6	24.5	20.2	17.15	11.03	9.28
1.83V	505	296	211	156	125.5	75.0	53.6	42.6	35.6	30.7	24.3	19.7	16.65	11.03	9.22
1.85V	478	289	196	149	121.5	72.6	52.1	42.0	34.8	30.1	23.6	19.6	16.45	10.83	9.14
MPG12V125F															
End voltage per cell	5min	15min	30min	45min	1h	2h	3h	4h	5h	6h	8h	10h	12h	20h	24h
1.60V	683	386	240	181	146.6	84.2	66.5	51.5	46.2	38.9	30.5	25.3	21.28	13.55	11.35
1.67V	658	379	238	180	145.6	84.0	65.6	51.4	46.0	39.0	30.1	25.2	21.08	13.45	11.35
1.70V	654	375	238	180	145.6	83.7	65.6	51.2	45.6	38.9	30.1	24.7	20.88	13.45	11.35
1.75V	611	372	237	179	142.6	83.2	65.0	51.1	45.3	38.8	29.8	24.6	20.88	13.35	11.35
1.80V	570	351	232	175	142.6	83.0	64.8	51.0	44.3	38.4	29.8	24.5	20.78	13.45	11.24
1.83V	549	322	229	170	136.5	81.9	63.3	49.2	43.3	37.2	29.5	23.9	20.38	13.35	11.24
1.85V	521	315	213	163	132.5	79.3	61.5	48.5	42.3	36.5	28.6	23.7	20.28	13.15	11.14
MPG12V150F															
End voltage per cell	5min	15min	30min	45min	1h	2h	3h	4h	5h	6h	8h	10h	12h	20h	24h
1.60V	955	540	336	253	203.8	117.5	85.9	68.1	57.4	49.5	38.4	31.4	26.51	16.97	14.26
1.67V	919	530	333	252	202.8	117.5	84.7	68.0	57.4	49.2	38.1	31.2	26.51	16.87	14.26
1.70V	913	524	333	251	202.8	116.5	84.7	67.7	56.6	48.8	37.9	31.0	26.20	16.87	14.16
1.75V	864	520	332	251	199.8	116.5	83.9	67.7	56.5	48.7	37.4	30.9	26.20	16.87	14.16
1.80V	793	491	324	245	198.8	115.5	83.6	67.5	55.6	48.2	37.4	30.8	26.20	16.87	14.16
1.83V	768	450	320	238	190.8	114.5	81.7	65.0	54.4	46.8	37.0	30.0	25.40	16.77	14.06
1.85V	728	439	298	228	184.7	110.4	79.5	64.2	53.0	45.9	35.9	29.8	25.10	16.47	13.96
MPG12V155F															
End voltage per cell	5min	15min	30min	45min	1h	2h	3h	4h	5h	6h	8h	10h	12h	20h	24h
1.60V	839	475	296	222	181.0	104.0	82.1	63.6	57.1	48.2	37.9	31.0	26.41	16.77	14.06
1.67V	809	466	293	221	180.0	104.0	81.0	63.5	56.8	48.2	37.4	30.8	26.20	16.67	14.06

1.70V	804	461	293	220	179.0	103.0	81.0	63.2	56.2	48.2	37.3	30.6	25.90	16.67	14.06
1.75V	750	457	292	220	177.0	103.0	80.2	63.2	55.9	48.0	36.9	30.5	25.90	16.67	14.06
1.80V	701	432	285	215	176.0	103.0	79.9	63.0	54.7	47.6	36.9	30.4	25.80	16.67	13.96
1.83V	676	396	282	208	169.0	101.0	78.1	60.7	53.5	46.2	36.5	29.6	25.30	16.57	13.86
1.85V	640	387	262	200	164.0	98.0	76.0	59.9	52.2	45.3	35.4	29.4	25.10	16.26	13.75
MPG12V170F															
End voltage per cell	5min	15min	30min	45min	1h	2h	3h	4h	5h	6h	8h	10h	12h	20h	24h
1.60V	1044	591	368	277	223.7	128.4	94.0	74.5	62.9	54.2	41.9	34.4	28.99	18.56	15.55
1.67V	1006	579	365	275	222.7	128.4	92.8	74.4	62.9	53.9	41.7	34.2	28.99	18.56	15.55
1.70V	1000	573	365	275	221.7	127.4	92.8	74.1	61.9	53.5	41.4	33.9	28.69	18.46	15.55
1.75V	934	568	363	275	218.7	127.4	91.8	74.0	61.9	53.3	41.0	33.9	28.69	18.46	15.55
1.80V	856	537	355	268	217.7	126.4	91.6	73.8	60.9	52.8	40.9	33.7	28.59	18.46	15.55
1.83V	818	493	350	260	208.6	125.4	89.5	71.1	59.6	51.2	40.5	32.9	27.78	18.35	15.35
1.85V	765	481	326	249	202.6	121.4	87.0	70.2	58.1	50.2	39.3	32.6	27.48	18.05	15.25
MPG12V200															
End voltage per cell	5min	15min	30min	45min	1h	2h	3h	4h	5h	6h	8h	10h	12h	20h	24h
1.60V	1096	619	386	290	233.9	134.5	106.4	82.3	73.9	62.2	48.8	40.1	34.04	21.59	18.07
1.67V	1055	608	383	288	232.9	134.5	105.4	82.2	73.6	62.1	48.3	39.8	33.73	21.59	18.07
1.70V	1048	601	383	288	231.9	133.5	105.4	81.9	72.9	62.2	48.2	39.6	33.43	21.49	18.07
1.75V	979	597	381	287	228.9	133.5	103.4	81.8	72.5	61.9	47.7	39.5	33.43	21.49	18.07
1.80V	914	563	372	280	227.9	132.5	103.4	81.6	70.8	61.3	47.7	39.3	33.33	21.49	18.07
1.83V	881	516	368	272	218.9	131.5	101.4	78.6	69.3	59.6	47.2	38.3	32.63	21.39	17.87
1.85V	835	504	342	261	211.8	126.5	98.4	77.6	67.6	58.4	45.8	38.0	32.43	20.98	17.77



## Chapter Three Operation and Maintenance

### 1. Operation Conditions

Ambient temperature: MPG series optimum temperature is 15°C~25°C, the higher and lower temperatures will impact battery performance

Operation temperature range

Operate status	Temperature range	Optimum temperature
Discharge	-40°C~50°C	15°C~25°C
Charge	-20°C~50°C	15°C~25°C
Storage	-20°C~40°C	15°C~25°C

Ambient humidity:  $\leq 95\%$

Cabinet ventilation conditions: meet the standard EN 50272-2:2001

### 2. Capacity

#### 2.1. Capacity of battery

The capacity of battery is the capacity that battery can be discharged on the established conditions, expressed as signal C. The usual unit of capacity is ampere hour, abbreviate AH.

The capacity can be expressed in Rated Capacity or Actual Capacity. The Rated Capacity of MPG batteries please see Table 1-1. The Actual Capacity is the product of the discharge current and the discharge time, the unit is AH.

#### 2.2. The Influence Factor of the Actual Capacity

The actual capacity is mainly related with the positive and negative active materials and their utilization ratio. The utilization ratio of the materials is mainly influenced by the DOD, the structure of the battery and manufacture technology. In using process the factors that influence the actual capacity are discharge rate, depth of discharge, end voltage and temperature.

#### 2.3. Discharge Rate

The discharge rate is often described as hour-rate and multiple rates.

If the discharge rate is higher and the discharge current is larger, then the discharge time is shorter, and the capacity which can be discharged is less.

#### 2.4. End voltage

The end voltage is the lowest working voltage below which the battery can't be discharged any more or it will harm the battery. Usually the 10hr rate end voltage of MPG battery is

1.80V/cell. The batteries are not able to discharge more capacity even if the end voltage is lower because of characteristics of gel battery, yet the low end voltage makes great harm to the battery. It will greatly shorten batteries' life especially to discharge the battery to 0V while not to recharge in time. Thus the end voltage should not be lower than what is described in table 3-2, or it will cause over-discharge and make recharge fail after several times of over-discharge.

**Table 3-2 Discharge End-voltage**

Discharge Current (A)	Discharge End Voltage (V/Cell)
$I < 0.2C$	1.80
$0.2C \leq I < 0.5C$	1.70
$0.5C \leq I < 1.0C$	1.55
$I \geq 1.0C$	1.30

### 3. Temperature

#### 3.1. Available Capacity Vs. Ambient Temperature

Temperature affects capacity of the battery. Fig. 3-1 is the available capacity curve vs. ambient temperature. if the temperature drops, the capacity will decrease, for example, the capacity will decrease to 85% of rated capacity if temperature decreases from 25°C to 0°C; and too low temperature will cause battery long term insufficient charged, also will cause no discharge and negative plates sulfate.

The MPG series using the polymer gel technology, this technology leverages on the advantages of the AGM and Tubular gel technology to provide the excellent temperature tolerance ability, the operation temperature range is -40°C to 50°C and the storage and transportation temperature range is -20°C to 40°C. The standard data is the test result at 25°C.

The standard data is the test result at 25°C, the capacity will increase when temperature raises. For example the capacity will increase to 102% of rated capacity if temperature increase from 25°C to 50°C. But it will quicken plates' corrosion and water loss if temperature raises, and shorten battery's life.

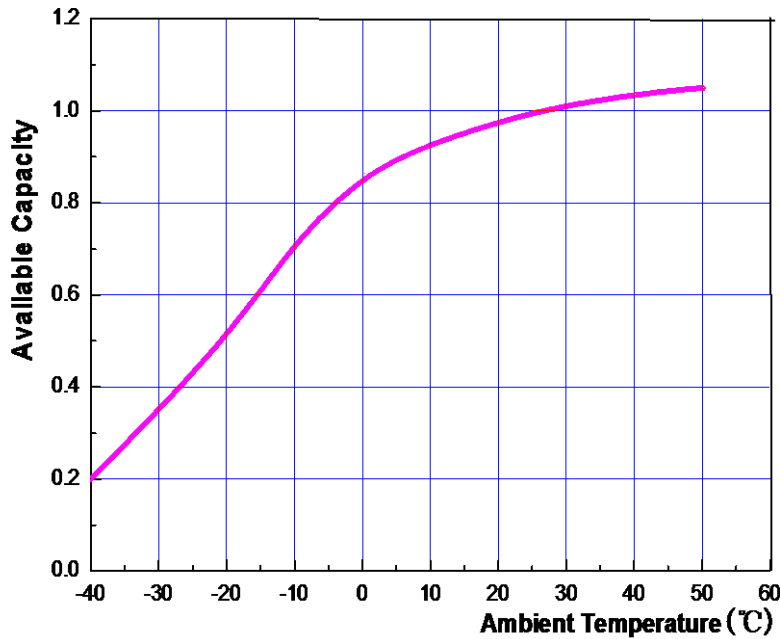

Fig.3-1 Available Capacity VS. Ambient Temperature

3.2. Temperature and Floating Voltage

The purpose of choosing proper floating voltage is to make the battery operate in a best condition. If the floating voltage is higher, then the floating current is also higher, it will accelerate corruption of the grid and shorten life of the battery. If the floating voltage is lower, the battery can't be kept in fully charged state; this will crystallize PbSO<sub>4</sub>, decrease the capacity, and also shorten the life of the battery.

At 25°C, the proper floating voltage for MPG series is 2.25V/cell. And temperature compensate coefficient is -3mV/°C/cell.

The formula to calculate float voltage at different temperature:

$$V_T = 2.25 - (T - 25) \times 0.003$$

V<sub>T</sub>—Floating charge voltage at T temperature

Table 3-2 Floating charge voltage at different temperature

Ambient Temperature (°C)	Floating Voltage (V/Cell)
≤5	2.31
10	2.30
15	2.28

20	2.27
25	2.25
30	2.24
35	2.22
≥40	2.21

Note: If ambient temperature below 5°C or above 40°C, temperature compensate is no longer go on.

### 3.3. Temperature and equalization charge

GEL battery needs equalization charge periodically to guarantee normal operation. At 25°C, the proper equalization voltage for MPG series is 2.4V/cell. And temperature compensate coefficient is -5mV/°C/cell.

The formula to calculate equalization voltage at different temperature:

$$V_T = 2.4 - (T - 25) \times 0.005$$

$V_T$ —Equalization charge voltage at T temperature

#### 3-3 Equalization charge voltage at different temperature

Ambient Temperature (°C)	Equalization charge Voltage (V/Cell)
≤5	2.50
10	2.48
15	2.45
20	2.43
25	2.40
30	2.38
35	2.35
≥40	2.33

Note: If ambient temperature below 5°C or above 40°C, temperature compensate is no longer go on.

### 3.4. Ambient Temperature Vs. Battery Life

Higher temperature will harm the battery and reduce battery life. When temperature exceeds 25°C, the battery life will decrease half per 10°C temperature raise. For example, the designed life of battery at 25°C is 5 years, when battery operates at 35°C, the actual life is only 2.5 years.

$$t_{25} = t_T \times 2^{(T-25)/10}$$

Notes: T the actual ambient temperature;

$t_T$  is designed life at T ambient temperature

$t_{25}$  is designed life at 25°C ambient temperature

The heats disseminate performance of GEL battery is bad, it's liable to cause thermal run away when heat accumulates. Please improve ventilation and temperature condition when room temperature is high. The distances between batteries should not be smaller than 10mm. Please also adjust the float voltage and equalization voltage according the manual.

#### 4. Charge and discharge requirements

##### 4.1. Equalization charge

Equalization charge is needed in following conditions:

- The voltage of at least two batteries are lower than 2.17V/cell
- Floating operation for more than three months

The method of equalization charge is: First charge the batteries on the constant current of not larger than  $0.2C_{20}A$  till the average voltage of the batteries increases to 2.40V/cell (25°C), then charge the batteries with constant voltage of 2.40V/cell, the time of equalization charge is 24 hours.

##### 4.2. Charge

Charge the batteries in following conditions. The method is same as that of equalization charge.

- After discharge
- Finish installation
- Storage time is above three months and open circuit voltage is lower than 2.10V/cell.

If battery need to be fully charged as soon as possible, then fast charge method can be adopted: limit current less than  $0.25C_{10}A$ , charge voltage 2.40V/cell (25°C) .

Whether the batteries are fully charged can be decided according to any one of two standards as follows:

- The charge time is 18-24 hours (the charge time can be shortened when the batteries were not deep discharged, e.g., the charge time of 20%DOD batteries can be shortened to 10 hours).
- On condition of constant voltage, the value of charge current hasn't varied for continuous

three hours.

### 5. Storage

All gel batteries experience self-discharge in open circuit. The result is that open circuit voltage decreases, and the capacity also decreases. During storage please note:

- The self-discharge rate is related with ambient temperature. The self-discharge rate is smaller when the ambient temperature is lower, otherwise is larger. The required temperature of MPG batteries' storage environment is from 0°C to 35°C. The storage place must be clean, ventilated and dry.

- An important parameter in storage is open circuit voltage, which is related with density of the electrolyte. If the open circuit voltage is lower than 2.17V/cell, or or storage period reach 3 to 6 months shown in following table, the batteries should be supplemental charged to avoid damage caused by self discharge.

Storage temperature	Max. Storage period
Above 30°C	3 months
Below 30°C	6 months

- All batteries, which are ready to store, should be fully charged before storage. It's suggested to record the storage time in the periodic maintenance record and record the time when another necessary supplemental charge should be made.

- The quality certificates and packages of MPG batteries record the latest charge time of the batteries, next charge time can be calculated according to this charge time.

Fig. 3-2 Available Capacity VS. Storage Time at Different Ambient Temperature。

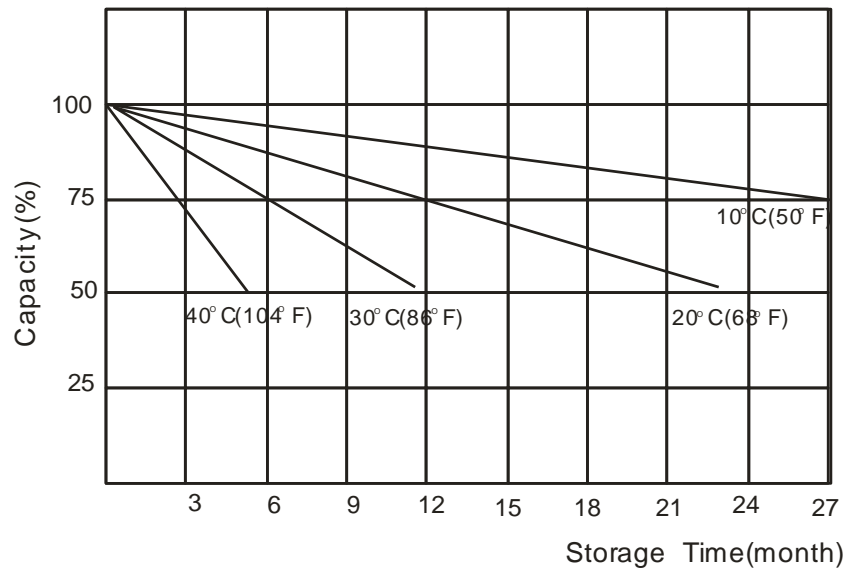

## 6. Maintenance

In order to assure service life, the batteries should be correctly inspected and maintained.

The maintenance methods of MPG batteries are recommended as follows

### 6.1. Monthly Maintenance

Implement following inspection every month:

- Keep the battery-room clean.
- Measure and record the ambient temperature of the battery-room.
- Check each battery's cleanness; check damage and overheating trace of the terminal, container and lid.
- Measure and record the total voltage and floating current of the battery system.

### 6.2. Quarterly Maintenance

- Repeat monthly inspection.
- Measure and record floating voltage of every on-line battery. If more than two cells' voltage is less than 2.17V/cell after temperature adjustment, the batteries need to be equalization charged. If the problem still exists after adopting above-mentioned measures, the batteries need yearly maintenance or even three years' maintenance. If all methods are ineffective, please contact us.

### 6.3. Yearly Maintenance

- Repeat quarterly maintenance and inspection.
- Check whether connectors are loose or not every year.

— Make a discharge test to check with exact load every year, discharging 30-40% of rated capacity.

#### 6.4. Three-year Maintenance

Make a 80% capacity test every year after three years' operation.

#### 6.5. Operation and Maintenance Precautions

##### — Insufficient Charge

If the floating voltage is not set correctly (too low or not amend according to temperature), the battery system will in an insufficient charge state for a long period of time. When the electricity is out, the battery may not be able to work and the capacity is decreased.

##### — Over Charge

Please do not neglect the performance of rectify to transfer floating charge to equalization charge. If the rectify cannot transfer charge modes because of its wrong performance or no adjustment, the battery system is always in an equalization charge state. Thus may cause serious problems for battery, such as water loss, life decrease, heat out of control, deformation, etc.

##### — Too low or too high temperature

We have mentioned that too low temperature will affect the capacity of battery. While too high temperature will also cause problems, such as water loss, life decrease, heat out of control, deformation, etc.

##### — Too low end voltage

The end voltage is also an important parameter for battery. The battery shall stop discharge when reach a certain voltage (The normal end voltage is 1.80V/cell per block at 10h rate). If the end voltage is too low, it will be difficult to recharge the battery and decrease the charge efficiency, thus reduce the life of battery.

##### — Put the battery aside after discharge

If the battery is put aside without charge for a long time after discharge, it will affect the capacity and life of the battery. Because some large size  $\text{PbSO}_4$  will create in the negative which are difficult to transfer to active Pb.



**After-sales Service / Customer Service Hotline**

**NARADA POWER SOURCE CO.,LTD.**

9F, Building A, No. 50 Zijinghua Road, Hangzhou, China

Tel: +86-571-56975980

Fax: +86-571-56975955

Website: [www.naradapower.com](http://www.naradapower.com) E -mail: [intl@narada.biz](mailto:intl@narada.biz)

**NARADA ASIA PACIFIC PTE. LTD.**

Block 9 Khaki Bukit Road 1 #02-10 Eunos Technolink, Singapore 415938

Email: [sales@narada-ap.com](mailto:sales@narada-ap.com)

Tel: +65-6848 1191 Fax: +65-6749 3498

Website: [www.narada-ap.com](http://www.narada-ap.com)

**NARADA EUROPE (UK) LIMITED**

Spectrum House, Dunstable Road, Redbourn, St. Albans, Herts AL3 7PR

Tel: +44 (0)845 612 2031

E-mail: [sales@naradaeurope.com](mailto:sales@naradaeurope.com)

**Annex 1**

GEL Battery Regular Maintenance Record

Type		Place	
Test Status		Qty	
Total Voltage (V)	Current(A)	Room Temperature	
No.	Voltage (V)	No.	Voltage (V)
1		13	
2		14	
3		15	
4		16	
5		17	
6		18	
7		19	
8		20	
9		21	
10		22	
11		23	
12		24	
Check by sight			
Result:			
Tester		Date	